

Technical leaflet

Solenoid valves 2/2-way servo-operated type EV220B 15-50

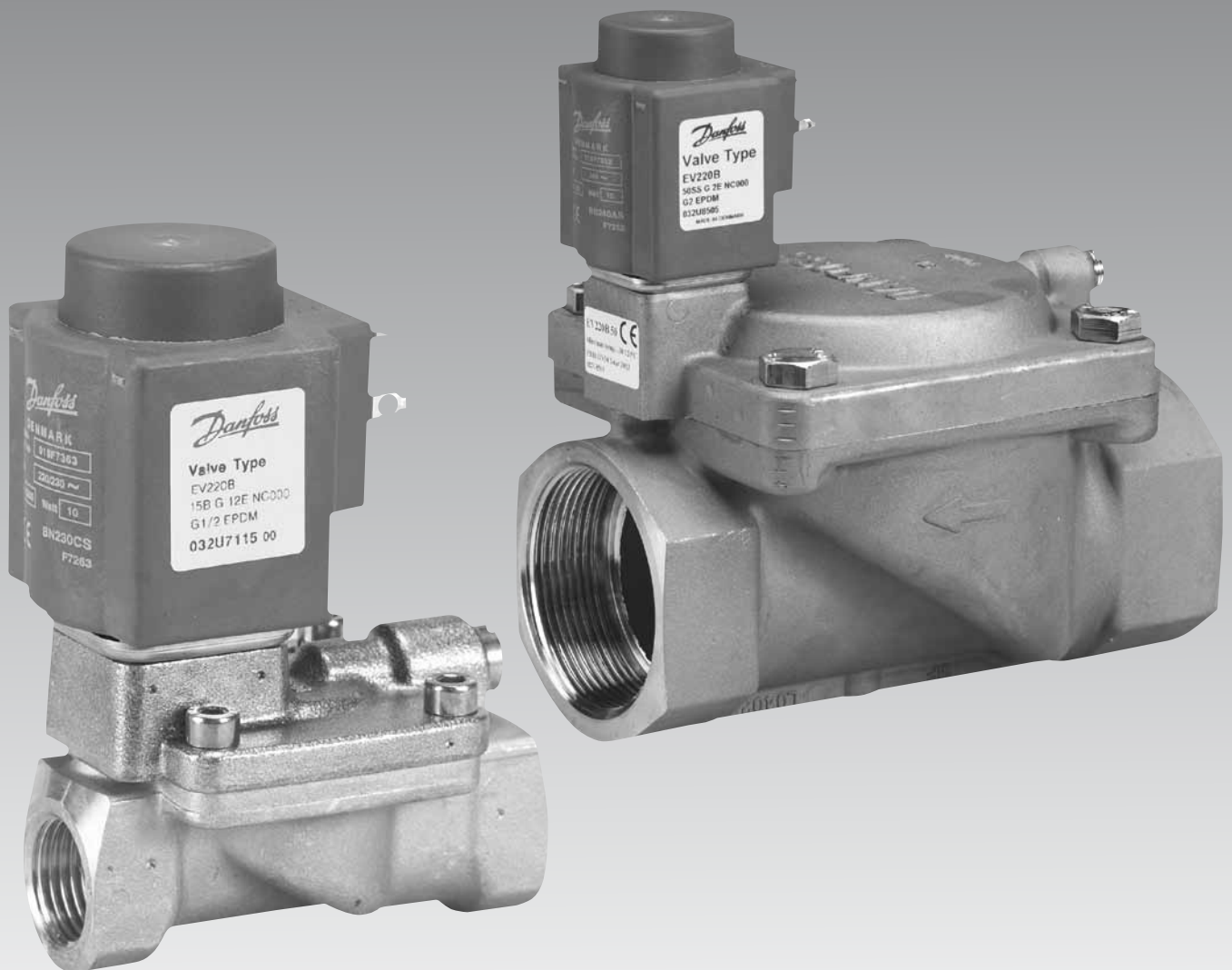

Contents	Page
EV220B 15-50B Normally Closed (NC)	
Introduction.....	3
Features.....	3
Approvals.....	3
Technical data.....	4
Function.....	4
Ordering.....	5
EV220B 15-50B Normally Open (NO)	
Function.....	6
Ordering.....	6
EV220B 15-50BD for slightly aggressive liquids and gases Normally Closed (NC)	
Features.....	7
Technical data.....	7
Ordering.....	7
EV220B 15-50SS Normally Closed (NC)	
Features.....	8
Technical data.....	8
Ordering.....	9
Coil options.....	9
Dimensions and weight.....	10
- Accessories	
Manual override unit.....	11
Isolating diaphragm kit.....	11
Equalizing orifice.....	11
- Spare parts	
Spare parts kit NC.....	12
Spare parts kit NO.....	12

Introduction

EV220B 15-50 is a universal indirect servo-operated 2/2 way solenoid valve program. Valve body in brass, dezincification resistant brass and stainless steel ensures that a broad variety of applications can be covered.

EV220B 15-50 valves are supplied complete or as separate components i.e valve body and coil, can be ordered separately.

Features

- For robust industrial application
- For water, steam, oil, compressed air and gases
- Flow range for water: 2.2 to 160 m³/h
- Differential pressure: Up to 16 bar
- Viscosity: Up to 50 cSt
- Ambient temperature: Up to +80°C
- Media temperature from -30°C to +140°C
- Coil enclosure: Up to IP 67
- Thread connections: From G ½ to G 2
- Water hammer damped
- Built in filter for protection of pilot system
- Adjustable closing time available (see page 11)
- Also available with NPT thread. Please contact Danfoss.

Approvals

EPDM versions in Normally Closed (NC) valves are WRAS approved.

Pressure Equipment Directive (PED) 97/23/EC

ATTESTATION DE CONFORMITE SANITAIRE, ACS	
Body material B = Brass with EPDM seal material	Body material SS = Stainless steel with EPDM seal material
EV220B 15B	EV220B 15SS
EV220B 20B	EV220B 20SS
EV220B 25B	EV220B 25SS
EV220B 32B	EV220B 32SS
EV220B 40B	EV220B 40SS
EV220B 50B	EV220B 50SS



Versions with UL approval can be supplied to order.

PAŃSTWOWY ZAKŁAD HIGIENY, PZH		
Body material B = Brass with EPDM seal material	Body material SS = Stainless steel with EPDM seal material	Body material BD = Dezincification resistant brass with EPDM seal material
EV220B 15B	EV220B 15SS	EV220B 15BD
EV220B 20B	EV220B 20SS	EV220B 20BD
EV220B 25B	EV220B 25SS	EV220B 25BD
EV220B 32B	EV220B 32SS	EV220B 32BD
EV220B 40B	EV220B 40SS	EV220B 40BD
EV220B 50B	EV220B 50SS	EV220B 50BD

Technical data

Main type	EV220B 15B	EV220B 20B	EV220B 25B	EV220B 32B	EV220B 40B	EV220B 50B
Installation	Optional, but vertical solenoid system is recommended.					
Pressure range	EPDM/NBR: 0.3 - 16 bar		0.3 - 10 bar for liquids on NO versions			
	FKM:		0.3 - 10 bar			
Max. test pressure	25 bar					
Time to open ¹⁾	40 ms	40 ms	300 ms	1000 ms	1500 ms	5000 ms
Time to close ¹⁾	350 ms	1000 ms	1000 ms	2500 ms	4000 ms	10000 ms
Ambient temperature	Type: BA 9 W ac/15 W dc Up to + 40°C Type: BB 10 W ac/18 W dc Up to + 80°C Type: BE 10 W ac/18 W dc (IP67) Up to + 80°C Type: BG 12 W ac/20 W dc Up to + 80°C Type: BO 10 W ac/10 W dc Up to + 40°C Type: BP 16 W dc Up to + 55°C					
Medium temperature	EPDM: -30 - + 120°C and +140°C / 4 bar (low pressure steam) FKM: 0 - +100°C and +60°C for water NBR: -10 - +90°C					
Viscosity	max. 50 cSt					
Materials	Valve body: Brass..... W.no. 2.0402 Armature: Stainless Steel, W.no. 1.4105/AISI 430 FR Armature tube: Stainless Steel, W.no. 1.4306/AISI 304 L Armature stop: Stainless Steel, W.no. 1.4105/AISI 430 FR Springs Stainless Steel, W.no. 1.4310/AISI 301 O-rings: EPDM, FKM or NBR Valve plate: EPDM, FKM or NBR Diaphragm: EPDM, FKM or NBR					

¹⁾ The times are indicative and apply to water. The exact times will depend on the pressure conditions. Closing times can be changed by replacement of the equalising orifice.

Function NC
Coil voltage disconnected (closed):

When the voltage is disconnected, the valve plate (3) is pressed down against the pilot orifice (4) by the armature spring (2). The pressure across the diaphragm (5) is built up via the equalising orifice (7). The diaphragm closes the main orifice (6) as soon as the pressure across the diaphragm is equivalent to the inlet pressure. The valve will be closed for as long as the voltage to the coil is disconnected.

Coil voltage connected (open):

When voltage is applied to the coil (1), the pilot orifice (4) is opened. As the pilot orifice is larger than the equalising orifice (7), the pressure across the diaphragm (5) drops and therefore it is lifted clear of the main orifice (6). The valve is now open for unimpeded flow and will be open for as long as the minimum differential pressure across the valve is maintained, and for as long as there is voltage to the coil.

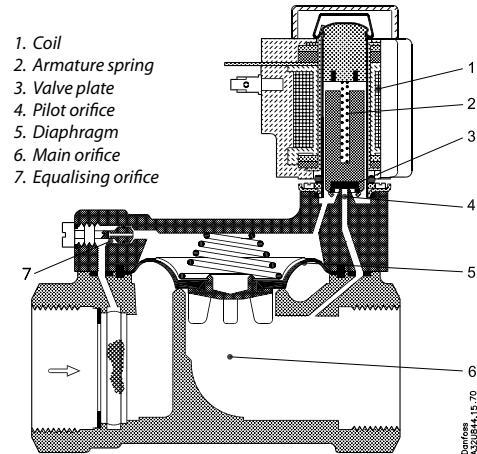

Ordering NC

Conne- ction ISO228/1	Seal material	k _v - value [m ³ /h]	Media temp.		Type designation		Pressure range all coil types		Code no. without coil	
			Min. [°C]	Max. [°C]	Main type	Specification	Min. [bar]	Max. ⁶⁾ [bar]		
G ½	EPDM ¹⁾ NBR ²⁾ FKM ³⁾	4	-30	+120 ⁴⁾	EV220B 15B	G 12E NC000	0.3	16	032U7115	
			-10	+90	EV220B 15B	G 12N NC000		16		032U7170
			0	+100 ⁵⁾	EV220B 15B	G 12F NC000		10		
G ¾	EPDM ¹⁾ NBR ²⁾ FKM ³⁾	8	-30	+120 ⁴⁾	EV220B 20B	G 34E NC000	0.3	16	032U7120	
			-10	+90	EV220B 20B	G 34N NC000		16		032U7171
			0	+100 ⁵⁾	EV220B 20B	G 34F NC000		10		
G 1	EPDM ¹⁾ NBR ²⁾ FKM ³⁾	11	-30	+120 ⁴⁾	EV220B 25B	G 1E NC000	0.3	16	032U7125	
			-10	+90	EV220B 25B	G 1N NC000		16		032U7172
			0	+100 ⁵⁾	EV220B 25B	G 1F NC000		10		
G 1 ¼	EPDM ¹⁾ NBR ²⁾ FKM ³⁾	18	-30	+120 ⁴⁾	EV220B 32B	G 114E NC000	0.3	16	032U7132	
			-10	+90	EV220B 32B	G 114N NC000		16		032U7173
			0	+100 ⁵⁾	EV220B 32B	G 114F NC000		10		
G 1 ½	EPDM ¹⁾ NBR ²⁾ FKM ³⁾	24	-30	+120 ⁴⁾	EV220B 40B	G 112E NC000	0.3	16	032U7140	
			-10	+90	EV220B 40B	G 112N NC000		16		032U7174
			0	+100 ⁵⁾	EV220B 40B	G 112F NC000		10		
G 2	EPDM ¹⁾ NBR ²⁾ FKM ³⁾	40	-30	+120 ⁴⁾	EV220B 50B	G 2E NC000	0.3	16	032U7150	
			-10	+90	EV220B 50B	G 2N NC000		16		032U7175
			0	+100 ⁵⁾	EV220B 50B	G 2F NC000		10		

¹⁾ EPDM is suitable for water and steam (steam max. +140° C / 4 bar).

²⁾ NBR is suitable for oil, water and air

³⁾ FKM is suitable for oil and air. For water at max. +60 °C

⁴⁾ Low pressure steam, 4 bar:Max. +140°C
BA ac/dc and BB/BE dc coils: Max. +100°C
BO and BP coils: Max. +90°C

⁵⁾ For water: Max. +60°C
BO and BP coils: Max. +90°C

⁶⁾ For higher differential pressure than stated, please contact Danfoss.

Function NO
Coil voltage disconnected (open):

When the voltage to the coil (2) is disconnected, the pilot orifice (4) is open. As the pilot orifice is larger than the equalising orifice (7), the pressure across the diaphragm (5) drops and therefore it is lifted clear of the main orifice (6). The valve will be open for as long as the minimum differential pressure across the valve is maintained, and for as long as the voltage to the coil is disconnected.

Coil voltage connected (closed):

When voltage is applied to the coil, the valve plate (3) is pressed down against the pilot orifice (4). The pressure across the diaphragm (5) is built up via the equalising orifice (7). The diaphragm closes the main orifice (6) as soon as the pressure across the diaphragm is equivalent to the inlet pressure. The valve will be closed for as long as there is voltage to the coil.

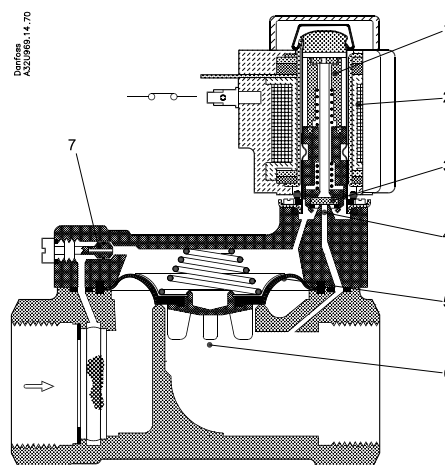

1. Armature
2. Coil
3. Valve plate
4. Pilot orifice
5. Diaphragm
6. Main orifice
7. Equalising orifice

Ordering NO

Connec- tion ISO228/1	Seal material	k _v - value [m ³ /h]	Media temp.		Type designation		Pressure range all coil types		Code no. without coil	
			Min. [°C]	Max. [°C]	Main type	Specification	Min. [bar]	Max. ⁶⁾ [bar] ⁷⁾		
G ½	EPDM ¹⁾ NBR ²⁾ FKM ³⁾	4	-30	+120 ⁴⁾	EV220B 15B	G 12E NO000	0.3	16	032U7117	
			-10	+90	EV220B 15B	G 12N NO000		16		032U7180
			0	+100 ⁵⁾	EV220B 15B	G 12F NO000		10		
G ¾	EPDM ¹⁾ NBR ²⁾ FKM ³⁾	8	-30	+120 ⁴⁾	EV220B 20B	G 34E NO000	0.3	16	032U7122	
			-10	+90	EV220B 20B	G 34N NO000		16		032U7181
			0	+100 ⁵⁾	EV220B 20B	G 34F NO000		10		
G 1	EPDM ¹⁾ NBR ²⁾ FKM ³⁾	11	-30	+120 ⁴⁾	EV220B 25B	G 1E NO000	0.3	16	032U7127	
			-10	+90	EV220B 25B	G 1N NO000		16		032U7182
			0	+100 ⁵⁾	EV220B 25B	G 1F NO000		10		
G 1 ¼	EPDM ¹⁾ NBR ²⁾ FKM ³⁾	18	-30	+120 ⁴⁾	EV220B 32B	G 114E NO000	0.3	16	032U7134	
			-10	+90	EV220B 32B	G 114N NO000		16		032U7183
			0	+100 ⁵⁾	EV220B 32B	G 114F NO000		10		
G 1 ½	EPDM ¹⁾ NBR ²⁾ FKM ³⁾	24	-30	+120 ⁴⁾	EV220B 40B	G 112E NO000	0.3	10	032U7142	
			-10	+90	EV220B 40B	G 112N NO000		10		032U7184
			0	+100 ⁵⁾	EV220B 40B	G 112F NO000		10		
G 2	EPDM ¹⁾ NBR ²⁾ FKM ³⁾	40	-30	+120 ⁴⁾	EV220B 50B	G 2E NO000	0.3	10	032U7152	
			-10	+90	EV220B 50B	G 2N NO000		10		032U7185
			0	+100 ⁵⁾	EV220B 50B	G 2F NO000		10		

1) EPDM is suitable for water and steam (steam max. +140° C / 4 bar).

2) NBR is suitable for oil, water and air

3) FKM is suitable for oil and air. For water at max. +60 °C

4) Low pressure steam, 4 bar: Max. +140°C

BA ac/dc and BB/BE dc coils: Max. +100°C

BO and BP coils: Max. +90°C

5) For water: Max. +60°C

BO and BP coils: Max. +90°C

6) For higher differential pressure than stated, please contact Danfoss.

7) Only 10 bars on liquids

Features

EV220BD for slightly aggressive liquids and gases.

- For robust industrial application
- For neutral and slightly aggressive liquids and gases.
- Contact Danfoss if you are in doubt about the valve's suitability for the medium in question.
- Differential pressure: Up to 16 bar
- Viscosity: Up to 50 cSt
- Ambient temperature: Up to +80°C
- Media temperature: from -30 to +140°C
- Coil enclosure: Up to IP 67
- Thread connections: From G ½ to G 2
- Water hammer damped
- Built in filter for protection of pilot system

Technical data

Main type	EV220B 15BD	EV220B 20BD	EV220B 25BD	EV220B 32BD	EV220B 40BD	EV220B 50BD
Installation	Optional, but vertical solenoid system is recommended.					
Pressure range	EPDM: 0.3 - 16 bar					
Max. test pressure	25 bar					
Time to open ¹⁾	40 ms	40 ms	300 ms	1000 ms	1500 ms	5000 ms
Time to close ¹⁾	350 ms	1000 ms	1000 ms	2500 ms	4000 ms	10000 ms
Ambient temperature	Type: BA 9 W ac/15 W dc Up to +40°C Type: BB 10W ac/18 W dc Up to +80°C Type: BE 10 W ac/18 W dc (IP67) Up to +80°C Type: BG 12 W ac/20 W dc Up to +80°C Type: BO 10 W ac/10 W dc Up to +40°C Type: BP 16 W dc Up to +55°C					
Medium temperature	EPDM: -30 - +120°C and +140°C / 4 bar (low pressure steam)					
Viscosity	max. 50 cSt					
Materials	Valve body: Dezincification resistant brass CuZn36Pb2As/CZ132 Armature: Stainless Steel,..... W.no. 1.4105/AISI 430 FR Armature tube: Stainless Steel,..... W.no. 1.4306/AISI 304 L Armature stop: Stainless Steel,..... W.no. 1.4105/AISI 430 FR Springs: Stainless Steel,..... W.no. 1.4310/AISI 301 Orifices: Stainless Steel,..... W.no. 1.4404/AISI 316L Valve seat: Stainless Steel,..... W.no. 1.4404/AISI 316L O-rings: EPDM Valve plate: EPDM Diaphragm: EPDM					

¹⁾ The times are indicative and apply to water. The exact times will depend on the pressure conditions. Closing times can be changed by replacement of the equalising orifice.

Ordering

Conec- tion ISO 228/1	Seal material	k _v - value [m ³ /h]	Media temp.		Type designation		Pressure range all coil types		Code no. without coil
			Min. [°C]	Max. [°C]	Maintype	Specification	Min. [bar]	Max. ³⁾ [bar]	Approved by WRAS
G ½	EPDM ¹⁾	4	-30	+120 ²⁾	EV220B 15BD	G 12E NC000	0.3	16	032U5815
G ¾	EPDM ¹⁾	8	-30	+120 ²⁾	EV220B 20BD	G 34E NC000	0.3	16	032U5820
G 1	EPDM ¹⁾	11	-30	+120 ²⁾	EV220B 25BD	G 1E NC000	0.3	16	032U5825
G 1 ¼	EPDM ¹⁾	18	-30	+120 ²⁾	EV220B 32BD	G 114E NC000	0.3	16	032U5832
G 1 ½	EPDM ¹⁾	24	-30	+120 ²⁾	EV220B 40BD	G 112E NC000	0.3	16	032U5840
G 2	EPDM ¹⁾	40	-30	+120 ²⁾	EV220B 50BD	G 2E NC000	0.3	16	032U5850

¹⁾ EPDM is suitable for water and steam (steam max. +140° C / 4 bar).

²⁾ Low pressure steam, 4 bar: Max. +140°C
 BA ac/dc and BB/BE dc coils: Max. +100°C
 BO and BP coils: Max. +90°C

³⁾ For higher differential pressure than started, please contact Danfoss.

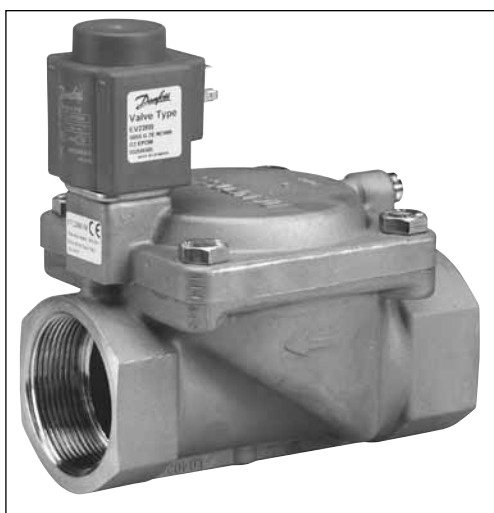
Features

EV220B Stainless Steel

- For robust industrial application
- For neutral and aggressive liquids and gases.
- Contact Danfoss if you are in doubt about the valve's suitability for the medium in question.
- Differential pressure: Up to 16 bar
- Viscosity: Up to 50 cSt
- Ambient temperature: Up to +80°C
- Media temperature: from -30 to +140°C
- Coil enclosure: Up to IP 67
- Thread connections: From G 1/2 to G 2
- Water hammer damped
- Built in filter for protection of pilot system

Technical data

Main type	EV220B 15SS	EV220B 20SS	EV220B 25SS	EV220B 32SS	EV220B 40SS	EV220B50SS
Installation	Optional, but vertical solenoid system is recommended.					
Pressure range	EPDM : 0.3 - 16 bar FKM: 0.3 - 10 bar					
Max. test pressure	25 bar					
Time to open ¹⁾	40 ms	40 ms	300 ms	1000 ms	1500 ms	5000 ms
Time to close ¹⁾	350 ms	1000 ms	1000 ms	2500 ms	4000 ms	10000 ms
Ambient temperature	Type: BA 9 W ac/15 W dc Up to + 40°C Type: BB 10W ac/18 W dc Up to + 80°C Type: BE 10 W ac/18 W dc (IP67) Up to + 80°C Type: BG 12 W ac/20 W dc Up to + 80°C Type: BO 10 W ac/10 W dc Up to + 40°C Type: BP 16 W dc Up to + 55°C					
Medium temperature	EPDM: -30 - + 120°C and +140°C / 4 bar (low pressure steam) FKM: 0 - +100°C and 60°C for water					
Viscosity	max. 50 cSt					
Materials	Valve body: Stainless Steel, W.no. 1.4581/AISI 318 Armature: Stainless Steel, W.no. 1.4105/AISI 430 FR Armature tube: Stainless Steel, W.no. 1.4306/AISI 304 L Armature stop: Stainless Steel, W.no. 1.4105/AISI 430 FR Springs: Stainless Steel, W.no. 1.4310/AISI 301 Orifices: Stainless Steel, W.no. 1.4404/AISI316L O-rings: EPDM or FKM Valve plate: EPDM or FKM Diaphragm: EPDM or FKM					

¹⁾ The times are indicative and apply to water. The exact times will depend on the pressure conditions. Closing times can be changed by replacement of the equalising orifice.

Ordering

Conec- tion ISO 228/1	Seal material	k _v - value	Media temp.		Type designation		Pressure range all coil types		Code no. without coil
			Min. [°C]	Max. [°C]	Maintype	Specification	Min. [bar]	Max. ⁵⁾ [bar]	
G ½	EPDM ¹⁾ FKM ²⁾	4	-30 0	+120 ³⁾ +100 ⁴⁾	EV220B 15SS	G 12E NC000	0.3	16 10	032U8500 032U8506
					EV220B 15SS	G 12F NC000			
G ¾	EPDM ¹⁾ FKM ²⁾	8	-30 0	+120 ³⁾ +100 ⁴⁾	EV220B 20SS	G 34E NC000	0.3	16 10	032U8501 032U8507
					EV220B 20SS	G 34F NC000			
G 1	EPDM ¹⁾ FKM ²⁾	11	-30 0	+120 ³⁾ +100 ⁴⁾	EV220B 25SS	G 1E NC000	0.3	16 10	032U8502 032U8508
					EV220B 25SS	G 1F NC000			
G 1 ¼	EPDM ¹⁾ FKM ²⁾	18	-30 0	+120 ³⁾ +100 ⁴⁾	EV220B 32SS	G 114E NC000	0.3	16 10	032U8503 032U8509
					EV220B 32SS	G 114F NC000			
G 1 ½	EPDM ¹⁾ FKM ²⁾	24	-30 0	+120 ³⁾ +100 ⁴⁾	EV220B 40SS	G 112E NC000	0.3	16 10	032U8504 032U8510
					EV220B 40SS	G 112F NC000			
G 2	EPDM ¹⁾ FKM ²⁾	40	-30 0	+120 ³⁾ +100 ⁴⁾	EV220B 50SS	G 2E NC000	0.3	16 10	032U8505 032U8511
					EV220B 50SS	G 2F NC000			

- 1) EPDM is suitable for water and steam (steam max. +140° C / 4 bar).
- 2) FKM is suitable for oil and air. For water at max. +60 °C
- 3) Low pressure steam, 4 bar:Max. +140°C
BA ac/dc and BB/BE dc coils: Max. +100°C
BO and BP coils: Max. +90°C
- 4) For water: Max. +60°C
BO and BP coils: Max. +90°C
- 5) For higher differential pressure than stated, please contact Danfoss.

Coil options



Type: BA
9 W ac
15 W dc



Type: BB
10 W ac
18 W dc

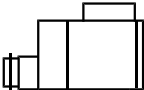

Type: BE (IP67)
10 W ac
18 W dc

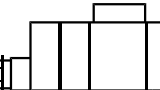

Type: BG
12 W ac
20 W dc

Danfoss also offers hum-free coils for noise sensitive applications and EEx m II T4 coils for use in explosion risk areas - please see coil data sheet IC.PD.600.A

Ordering Coils

See separate data sheet for coils IC.PD.600.A

Dimensions and weight

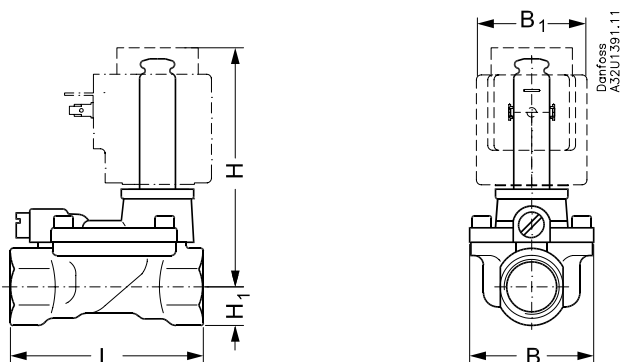

Type	L [mm]	B [mm]	B ₁ [mm] Coil type				H ₁ [mm]	H [mm]	Weight without coil [Kg]
			BA	BP	BB/BE	BG/BO			
EV220B 15	80.0	52.0	32	45	46	68	15.0	99.0	0.8
EV220B 20	90.0	58.0	32	45	46	68	18.0	103.0	1.0
EV220B 25	109.0	70.0	32	45	46	68	22.0	113.0	1.4
EV220B 32	120.0	82.0	32	45	46	68	27.0	120.0	2.0
EV220B 40	130.0	95.0	32	45	46	68	32.0	129.0	3.2
EV220B 50	162.0	113.0	32	45	46	68	37.0	135.0	4.3

Accessories

Manuel override unit

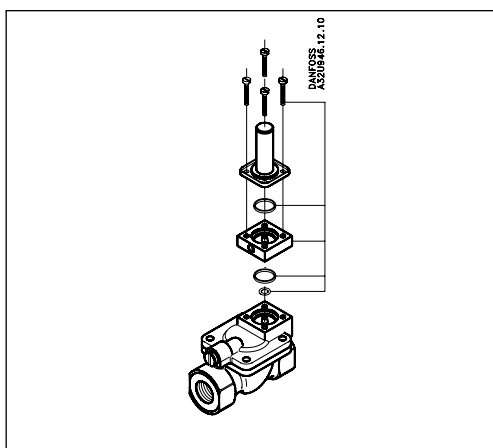

Used for manual override in event of power failure.

Note: Valve height is increased by 16 mm.

Material	Code no.
Brass, size DN 15-32	032U0150
Brass, size DN 40-50	032U0260
Stainless steel	032U0149

Isolating diaphragm kit

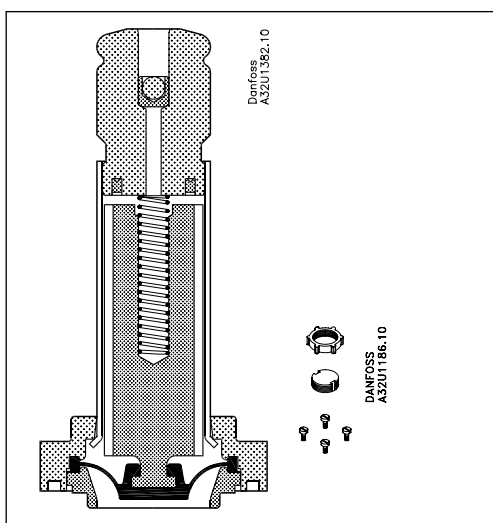

The isolating diaphragm design ensures that no fluid enters the armature area, which gives the following advantages:

The valve is resistant to aggressive fluids, impurities in the fluid and to calcareous and scale deposits.

The kit consists of assembled isolating unit, O-ring, 4 screws, locking button and nut for the coil.

The kit can be used on all EV220B DN 15-50 and EV210B DN 1.5-3 valves.

Seal material	Code no.
EPDM ¹⁾	042U1009
FKM ²⁾	042U1010

¹⁾EPDM is suitable for water.

²⁾FKM is suitable for oil and air. For water at max.+60°C

Equalizing orifice

The kit comprises an equalizing orifice including O-ring and gasket. The valve's closing time can be changed by installing an equalizing orifice of a size which deviates from the standard valve:

- A shorter closing time is obtained with a larger orifice (the shorter closing time, the greater risk of water hammering)
- A longer closing time is obtained with a smaller orifice.

Orifice	Seal material	Standard in	Code no.	
			Brass	DZR brass ⁴⁾ / Stainless steel
ø 0.5	EPDM ¹⁾	EV220B 15 EV220B 20	032U0082	032U6310
ø 0.5	FKM ²⁾	EV220B 15 EV220B 20	032U0083	032U6313
ø 0.8	EPDM ¹⁾	EV220B 25 EV220B 32 EV220B 40	032U0084	032U6311
ø 1.2	FKM ²⁾	EV220B 25 EV220B 32	032U0085	032U6314
ø 1.2	EPDM ¹⁾	EV220B 50	032U0086	032U6312
ø 1.4	FKM ²⁾	EV220B 40 EV220B 50	032U0087	032U6315
Adjustable	NBR ³⁾	-	032U0681	-
Adjustable	EPDM ¹⁾	-	032U0682	-
Adjustable	FKM ²⁾	-	032U0683	-

1) Approved by WRAS.

Approved by Attestation de Conformite Sanitaire (ACS)

EPDM is suitable for water and steam (steam max. +140°C / 4 bar)

2) FKM is suitable for oil and air.

For water at max. +60°C.

3) NBR is suitable for oil, water and air.

4) Dezincification resistant brass.

Spare parts

Spare parts kit (NC)

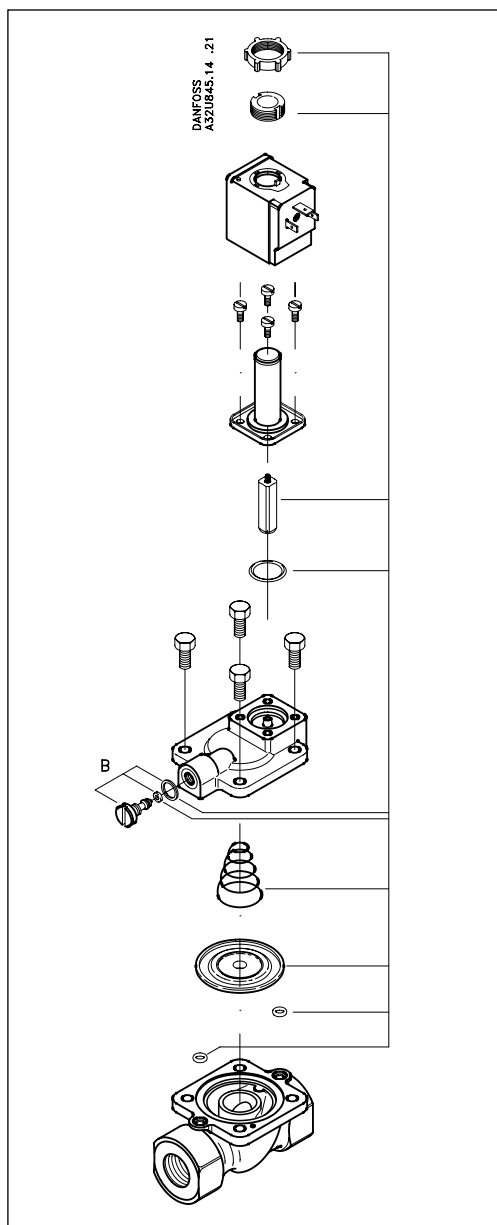

The kit comprises a locking button and nut for the coil, armature with valve plate and spring, O-ring for the armature tube, spring and diaphragm, two O-rings for the pilot system, and an O-ring and gasket for the equalising orifice.

Brass versions		
Type	Seal material	Code no.
EV220B 15	EPDM ¹⁾	032U1071
	FKM ²⁾	032U1072
	NBR ³⁾	032U6013
EV220B 20	EPDM ¹⁾	032U1073
	FKM ²⁾	032U1074
	NBR ³⁾	032U6014
EV220B 25	EPDM ¹⁾	032U1075
	FKM ²⁾	032U1076
	NBR ³⁾	032U6015
EV220B 32	EPDM ¹⁾	032U1077
	FKM ²⁾	032U1078
	NBR ³⁾	032U6016
EV220B 40	EPDM ¹⁾	032U1079
	FKM ²⁾	032U1080
	NBR ³⁾	032U6017
EV220B 50	EPDM ¹⁾	032U1081
	FKM ²⁾	032U1082
	NBR ³⁾	032U6018

DZR brass ⁴⁾ and stainless steel versions		
Type	Seal material	Code no.
EV220B 15	EPDM ¹⁾	032U6320
	FKM ²⁾	032U6326
EV220B 20	EPDM ¹⁾	032U6321
	FKM ²⁾	032U6327
EV220B 25	EPDM ¹⁾	032U6322
	FKM ²⁾	032U6328
EV220B 32	EPDM ¹⁾	032U6323
	FKM ²⁾	032U6329
EV220B 40	EPDM ¹⁾	032U6324
	FKM ²⁾	032U6330
EV220B 50	EPDM ¹⁾	032U6325
	FKM ²⁾	032U6331

- ¹⁾ Approved by WRAS.
Approved by Attestation de Conformite Sanitaire (ACS)
EPDM is suitable for water and steam (steam max. +140°C / 4 bar).
- ²⁾ FKM is suitable for oil and air. For water at max. +60°C
- ³⁾ NBR is suitable for oil, water and air
- ⁴⁾ Dezincification resistant brass

Spare parts kit (NO)

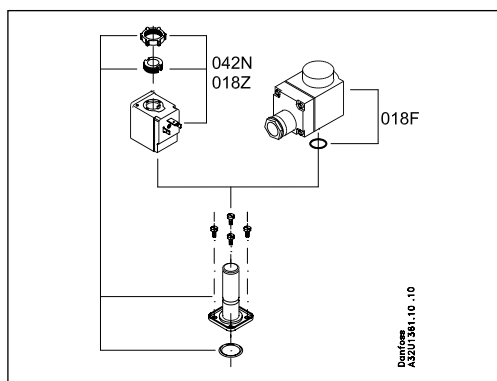

The kit comprises a locking button and nut for the coil, Armature unit assembly, O-ring for the armature unit.

Type	Seal material	Code no.
EV220B 15-50	EPDM ¹⁾	032U0296
	FKM ²⁾	032U0295
	NBR ³⁾	032U0299

- ¹⁾ EPDM is suitable for water and steam (steam max. +140°C / 4 bar).
- ²⁾ FKM is suitable for oil and air. For water at max. +60°C
- ³⁾ NBR is suitable for oil, water and air.